

PORTIQUES



GUIDE TECHNIQUE TECHNICAL GUIDE

Portiques
Gantry cranes

 **VERLINDE**
LIFTING EQUIPMENT

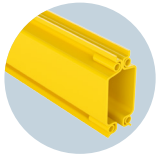

VGPS

Portiques d'atelier profil creux EUROSYSTEM ST EUROSYSTEM ST hollow-section workshop gantry cranes



> Description

- > Portique d'atelier profil creux EUROSYSTEM ST monté sur roues pivotantes.
- > Utilisation en intérieur uniquement.
- > PORTIQUES NON DEPLAÇABLES EN CHARGE.
- > Construction mécano-soudée, démontable en 3 éléments.
- > Roues en polyamide blanc.
- > Livré avec chariot porte charge et ligne d'alimentation.
- > Protection : système 3 couches.
- > Finition polyuréthane RAL 1028.
- > Vitesse de levage maximum = 8 m/min.

> Options

- > Roues à blocage.
- > Roues non pivotantes.
- > Interrupteur cadenassable.
- > Peinture autre que RAL 1028.
- > Dimensions adaptées au besoin.
- > Palan électrique ou manuel.

> Description

- > EUROSYSTEM ST hollow-section workshop gantry crane mounted on rotating wheels.
- > For indoor use only.
- > GANTRY CRANES ARE NOT MOVABLE UNDER LOAD.
- > Mechanically welded construction can be dismantled into 3 parts.
- > White polyamide wheels.
- > Load trolley and power supply cable provided.
- > Protection: 3 layers.
- > RAL 1028 yellow polyurethane finish.
- > Maximum hoisting speed = 8m/min.

> Options

- > Locking wheels.
- > Non-rotating wheels.
- > Lockable main switch.
- > Paint choice alternatives to RAL 1028.
- > Size adjusted to your needs.
- > Electric or manual hoist.

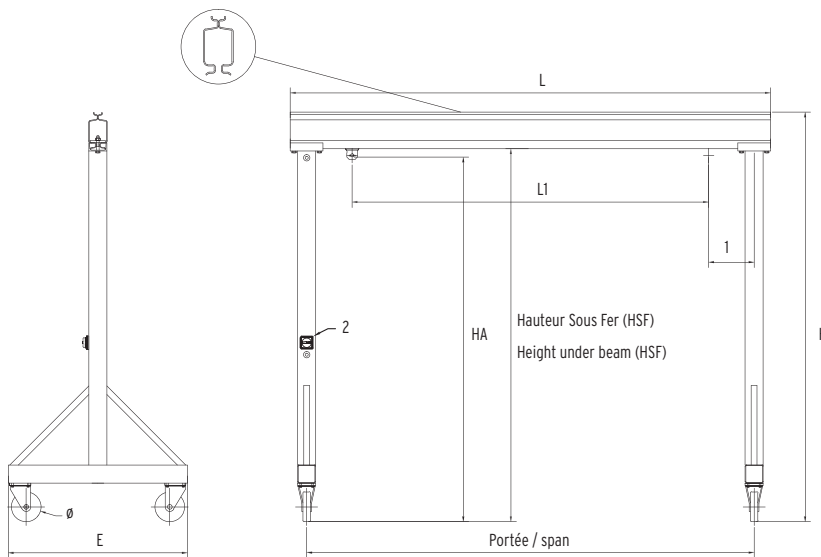

HA	Hauteur d'accrochage Height of hanging
1	200 mm pour 500 Kg et 1000 KG 200 mm for 500 Kg and 1000 KG
2	315 mm pour 1600 Kg et 2000 KG 315 mm for 1600 Kg and 2000 KG
2	Interrupteur cadenassable (option) Lockable main switch (option)

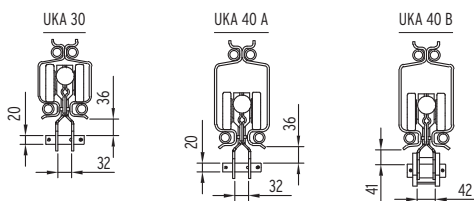

CMU	Portée	Hauteur sous fer (HSF)	H	HA	L	L1	E	Ø	Chariot	Poids
Max. capacity	Span	Height under beam (HSF)							Trolley	Weight
KG	m	m	m	m	m	m	m	mm	N°	Kg
500	2				2,22	1,39				180
	3	2,00	2,18	1,96	3,22	2,39	1,20	150	30	199
	4				4,22	3,39				218
	5				5,22	4,39				237
	2				2,22	1,39				190
	3	2,50	2,68	2,46	3,22	2,39	1,20	150	30	209
	4				4,22	3,39				228
	5				5,22	4,39				247
	2				2,22	1,39				200
	3	3,00	3,18	2,96	3,22	2,39	1,50	150	30	219
	4				4,22	3,39				238
	5				5,22	4,39				257
	2				2,22	1,39				210
	3	3,50	3,68	3,46	3,22	2,39	1,50	150	30	229
	4				4,22	3,39				248
5				5,22	4,39				267	
1 000	2				2,22	1,39				199
	3	2,00	2,18	1,96	3,22	2,39	1,20	150	30	218
	4				4,22	3,39				237
	5		2,22		5,22	4,39			40 A	306
	2				2,22	1,39				210
	3	2,50	2,68	2,46	3,22	2,39	1,20	150	30	229
	4				4,22	3,39				248
	5		2,72		5,22	4,39			40 A	317
	2				2,22	1,39				221
	3	3,00	3,18	2,96	3,22	2,39	1,50	150	30	240
	4				4,22	3,39				259
	5		3,22		5,22	4,39			40 A	328
	2				2,22	1,39				232
	3	3,50	3,68	3,46	3,22	2,39	1,50	150	30	251
	4				4,22	3,39				270
5		3,72		5,22	4,39			40 A	339	
1 600	2				2,22	1,14				220
	3	2,00	2,22	1,96	3,22	2,14	1,20	200	40 B	269
	4				4,22	3,14				298
	5				5,22	4,14				327
	2				2,22	1,14				234
	3	2,50	2,72	2,46	3,22	2,14	1,20	200	40 B	283
	4				4,22	3,14				312
	5				5,22	4,14				341
	2				2,22	1,14				248
	3	3,00	3,22	2,96	3,22	2,14	1,50	200	40 B	297
	4				4,22	3,14				326
	5				5,22	4,14				355
	2				2,22	1,14				262
	3	3,50	3,72	3,46	3,22	2,14	1,50	200	40 B	311
	4				4,22	3,14				340
5				5,22	4,14				369	
2 000	2				2,22	1,14				271
	3	2,00	2,22	1,96	3,22	2,14	1,20	200	40 B	300
	4				4,22	3,14				329
	2				2,22	1,14				287
	3	2,50	2,72	2,46	3,22	2,14	1,20	200	40 B	316
	4				4,22	3,14				345
	2				2,22	1,14				263
	3	3,00	3,22	2,96	3,22	2,14	1,50	200	40 B	332
	4				4,22	3,14				361
	2				2,22	1,14				279
	3	3,50	3,72	3,46	3,22	2,14	1,50	200	40 B	348
	4				4,22	3,14				377

VERLINDE, c'est :

- Le premier constructeur et exportateur français d'équipement de levage et de manutention.
- Une gamme continue de 30 familles de matériel de levage de 60 à 250 000 kg.
- La certification assurance qualité ISO 9001 et système de management environnemental ISO 14001.

En France :

Un réseau d'agences commerciales, des stations service après vente, des unités de fabrication de ponts roulants EUROPONT et un réseau de distributeurs.

Reste du monde :

Un interlocuteur à vos côtés dans plus de 92 pays.



Nos références / Our references

Métallurgie, Mécanique, Nucléaire / Metallurgy, Mechanics, Nuclear → ArcelorMittal - Unimetal - Stein - NFM - Framatome - Alstom

Industrie Chimie, Pétro-chimie / Chemicals, Petrochemicals industry → Sanofi Aventis - Du Pont De Nemours - Total

Industrie aéronautique / Aeronautical industry → Aérospatiale - Airbus - Eurocopter - Air France - Aéroport de Paris - Snecma - Dassault Aviation

Industrie agro-alimentaire / Agri-food industry → Nestlé - Danone - Bel - Palamatic - Tetrapak - Lactalis

Industrie automobile / Automobile industry → Renault - Peugeot - Citroën - Scania - Ford - RVI - Volkswagen - Michelin - Massey Ferguson - Manitou - Toyota Industrial Equipment

Autres secteurs / Other sectors → EDF - SNCF - RATP - Spie - Degremont - Eiffage - Polysius - Baudin Chateaufort



VERLINDE is:

- The leading French manufacturer and exporter of lifting and handling equipment.
- A comprehensive range of 30 groups of lifting equipment from 60 to 250,000 kg.
- ISO 9001 Quality control certified and ISO 14001 Environmental Management Systems.

In France:

A sales network and after sales service points, EUROPONT travelling crane construction plants and a distributor network.

Abroad:

A customer service in more than 92 countries.



2, boulevard de l'Industrie - B.P. 20059 - 28509 Vernouillet cedex - France

Téléphone : (33) 02 37 38 95 95 - Fax : (33) 02 37 38 95 99

Internet : www.verlinde.com